



Fertilizer Transportation Sampling

International Fertilizer Industry Association (IFA)

International Fertilizer Industry Association (IFA) - 28, rue Marbeuf - 75008 Paris - France
Tel. +33 1 53 93 05 00 - Fax +33 1 53 93 05 45/47 - ifa@fertilizer.org - www.fertilizer.org

This recommendation was prepared by the IFA Working Group on the Harmonization of Fertilizer Sampling and Methods of Analysis. This document is available to the general public and is a reference document for the international trade of fertilizer products. It should not be considered to be an international standard; nor does this document take precedence over existing national and regional regulations or standards.

This recommendation and its background documents are available to the general public on the IFA web site (www.fertilizer.org), or through written request to the IFA Secretariat.

Copyright © 2015 International Fertilizer Industry Association - All Rights Reserved

Contents

Introduction	1
--------------------	---

Transportation sampling of material from loaded trucks, railcars, bulk containers, and barge is a common request.....	1
---	---

Table

Table 1. Industry manual sampling methods and procedures for transportation sampling.....	4
---	---

Figures

Figure 1. ISO sampling pattern	6
Figure 2. TFI sampling pattern	6
Figure 3. Fertilizer Control Order (FCO) sampling pattern.....	6
Figure 4. TFI sampling pattern – Hatch cover.....	6
Figure 5. AOAC sampling plan – Hopper cars.....	6
Figure 6. Flat-bottomed shovel or scoop with vertical sides.....	6
Figure 7. Double tube trier	6
Figure 8. Transfer of core sample from Missouri “D” tube into intermediate container.....	6
Figure 9. Example of Mechanical Probe Sampler.....	7
Figure 10. Example of Mechanical Probe Sampler.....	7

Fertilizer Transportation Sampling (Truck, Railcar, Bulk Container, Ship / Barge Hold)

Introduction

With the acceleration of global fertilizer trade, IFA's diverse membership has experienced an increasing number of contractual disputes due to the use of different methods and procedures to sample and analyze international product shipments at different points in the supply chain. In a member-driven initiative, a broad-based international task force was formed to address this matter.

Accurate and representative sampling is a challenging operation that requires both knowledge of the product as well as the correct application of the sampling process. Sampling procedures must be applied in a strict manner by trained personnel with prior sampling experience. Moreover, a standardized approach must be adopted irrespective of the sampling location, shipment mass or volume, or commodity.

Transportation sampling of material from loaded trucks, railcars, bulk containers, and barge is a common request

Mechanical Probe Sampling

For operating sites where the preferred full stream mechanical sampling systems are not available, stationary bulk materials from trucks, rail cars, bulk containers or barges can be sampled by means of a mechanical probe sampling system.

Mechanical probe sampling systems result in more accurate, representational results than manual "car top" sampling.

Mechanical probe sampling systems have advantages over manual techniques:

1. Well-designed mechanical probe systems allow for a more reliable means to extract and collect primary increments from a vertical column at desired point and depth;
2. This procedure reduces health and safety risk to sampling personnel as it avoids manual sampling from top of loaded trucks, railcars, containers or barges.

It is essential that mechanical sampling systems be regularly inspected and audited to ensure correct sampling and compliance to original design and applicable standards.

Manual Sampling

In the absence of a mechanical sampling system, manual sampling may be carried out on fertilizer material being transported by truck, railcar, bulk container or barge. **Table 1** lists various industry manual sampling methods and procedures for transportation sampling. Comparably, the methods listed follow the same principle with basic, minimum conditions that must be fulfilled to ensure that a sample of fertilizer fairly represents the lot of fertilizer from which the sample is taken. These minimum conditions are as follows:

- A. Determine the purpose for which the sample is required and determine the characteristics of the material, i.e., its estimated quality, maximum particle size, homogeneity, etc.;
- B. Determine the number of sampling units for the shipment. The number of sampling units should be taken as the square root of the number of units (packaged product) or the square root of 4 times the total tonnage (bulk) present in the lot or shipment, with 10 units being the minimum;
- C. Select at random 10 sampling units to be sampled. Incremental samples shall be taken from the 10 selected sampling units;
- D. Use a standard sampling pattern so that each increment represents an approximate equal fraction of the whole;
- E. Obtain a sample that consists of approximately equal portions (increments) drawn from each sample location;
- F. Obtain a sample of a sufficient mass or volume for the required analyses.

For industry quality control purposes, a "lot" shall be represented by the quantity of a given product made during a specified time period, in storage at a single location, or shipped from a single production point.

When transporting a "lot" e.g. in multiple railcars, trucks and barges a sampling unit can be regarded as a single rail car, a separate hold or an imaginary division of the surface of the product. Ensure that a minimum of 10 sampling units are considered and define the sampling scheme for the minimum number of increments to be taken from each unit. Example: Up to 100 railcars the minimum number of railcars to be sampled would be ten, with increments taken from each selected railcar.

Sampling from Ships Holds – There may be a request or need to sample product in a static condition from a ship or vessel's hold. Due to the typical size of a vessel hold it is recommended that each hold be sampled as an individual lot, obtaining a minimum of 10 equally distributed increments from randomly selected sampling units in each hold.

For the sampling of vessel's with product in a dynamic condition refer to "IFA Recommended Best Practices for the Sampling of Dry Bulk Fertilizer Shipments".

Experience has demonstrated that sampling methods (and samples), all other conditions being equal, are more reliable whenever a larger number of (unbiased) increments are collected.

It should be noted that, while the basic sampling methods outlined are comparable in principle, due care must be followed in utilizing proper sampling equipment / apparatus for the material being sampled. Studies have concluded that the double tube trier (spear) is the recommended apparatus for probe sampling; however, the dimensions of the trier have to be appropriate to the characteristics of the sample portion and to the particle size of the fertilizer. Increments collected should be stored immediately in moisture-impervious containers (if moisture is a concern / specification), but always in a container capable of preserving the integrity of the collected increments.

Conditions such as segregation, heterogeneity, stratification, contamination, etc. must be considered if bias is to be avoided and if sampling and sample preparation variance are to be minimized.

Manual sampling of the type described above (from loaded trucks, cars, bulk containers, vessel holds, etc.) does not satisfy the minimum requirements for probability sampling, and as such should not be used to draw statistical inferences such as precision, standard error, or bias.

For more reliable methods that provide probability samples, it is recommended that, whenever possible, sample increments should be collected during loading or during material transport, i.e., while the material is in movement.

During any sampling operation, consideration must be given to conditions that help to minimize health and safety risks to personnel.

Disclaimer:

Manual sampling from the top of loaded Truck, Railcar or Bulk Container (car top) is a dangerous activity and should only be carried out from a safe location such as loading rack or platform.

Car top sampling should only be performed in locations and facilities where such an activity is permitted in accordance with the local facilities health and safety rules.

While recognizing that car top sampling is common practice in many locations, IFA does not accept any responsibility for any incident that may result from the execution of such sampling activities, nor for any of the other activities described in this paper.

Table 1. Industry manual sampling methods and procedures for transportation sampling.

<i>Standard</i>	<i>Number of increments</i>	<i>Mass of increment</i>	<i>Sampling place / depth of probe</i>	<i>Apparatus</i>	<i>Sample container</i>	<i>Sample Division</i>	<i>Remarks / Region in use</i>
AOAC 929.01	10	Not defined	Deep probing form surface	Double tube triers "Missouri" "Missouri D" "552 Grain"	Airtight container	Riffle divider	
ISO 8633:1992	10, up to 5 mt √tonnage x 20 10, up to 25 mt	Minimum mass of increment as per ISO/TR 7553	From surface	Flat-bottomed shovel or scoop with vertical sides. Spear can be used provided it can collect increments more than the minimum mass and is appropriate for sample particle size	Sealable, airtight container	Riffle, cone sample divider, automatic rotary sample divider provided it does not separate out particle size	Internationally recognized.
GOST 21560.0 Trucks	< 5 mt – 7 increments > 5 mt – 10 increments	no less than 200g	From Surface		Clean and dry jar with lid, or double plastic bag which should be sealed	Rotating divider or riffle divider, average sample 1 to 2.5 kg	Russia and other FSU countries
Railcars (covered, side opened)	36 increments		Inside of railcar	Scoop or Single Tube Trier.			
TFI, Fertiliser sampling and analytical methods, 4th Edition					Double tube triers "Missouri" "Missouri D" "552 Grain"	Corrosion-resistant, airtight container	Riffle divider
Trucks, opened railcars	10 increments		Not defined	From surface Not less 4 feet (1.2 m) depth			
Multi-Compartment Trucks	10 per each compartment						
Hopper cars	3-4 hatches – 4 probes per hatch >4 hatches – 2 probes per hatch						

Standard	Number of increments	Mass of increment	Sampling place / depth of probe	Apparatus	Sample container	Sample Division	Remarks / Region in use
KEBS Kenya Bureau of Standards Sampling of Fertilizers for the purpose of PVOC Kenya February 2009	10	Not defined	From Surface "Draw to the maximum possible depth"	Not defined	Airtight container	Not defined	
FAI, The Fertiliser (control) order 1985 (as amended up to June 2006) Vessel's Holds / hatches Trucks	10 - 15 increments from each hatch and from different depths and different points during unloading operations 10 vertical probes, as per scheme	Not defined Not defined	Deep probe from surface Deep probe from surface	Sampling probe –slotted double tube (stainless steel or brass), dimension 4 ½ ft – 5 ft in length and 1 ¼ in - 1 ½ in in diameter Sampling probe –slotted double tube (stainless steel or brass), dimension 4 ½ ft – 5 ft in length	Clean, dry and airtight glass or screwed hard polythene bottle 400 g capacity or thick gauged polythene bag	Portions should be mixed as possible by suitable means	India
AFPC VI.1 Trucks and Hopper cars, Railcars Ship Hold	10 vertical cores (for multi-compartmented sampling pattern used for each compartment) 10 increments per each 10 m ² from top, middle, and bottom levels	Not defined	Deep probe from surface (depth not less than 4 ft)	Missouri trier Preferred tools 1.5 m length, ¾ in in diameter	Water-proof container		USA, Internationally

Sampling Schemes

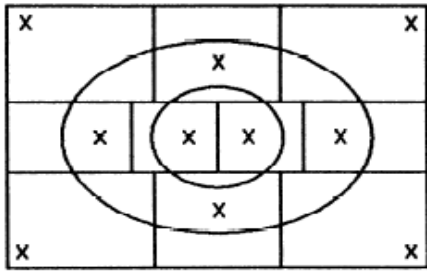

Figure 1. ISO sampling pattern.

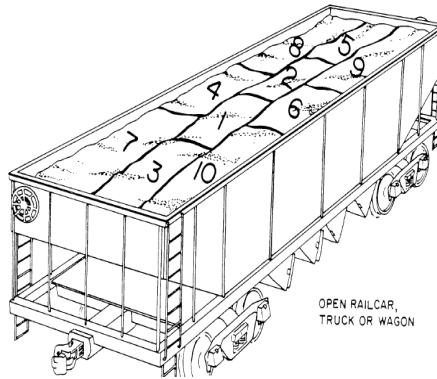

Figure 2. TFI sampling pattern.

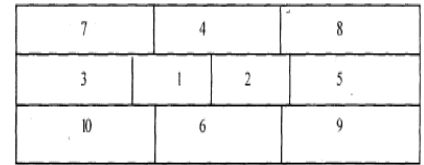
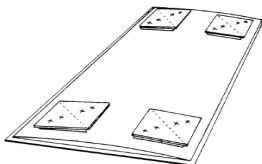
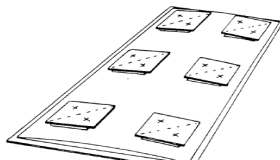

Figure 3. Fertilizer Control Order (FCO) sampling pattern.



PATTERN A
(3-4 HATCHES)
4 probes/hatch



PATTERN B
(MORE THAN 4 HATCHES)
2 probes/hatch

Figure 4. TFI sampling pattern – Hatch cover.

Sampling Points for Hopper Cars

Pattern A
4 probes/hatch

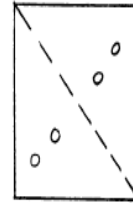

Pattern B
2 probes/hatch

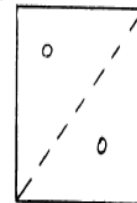
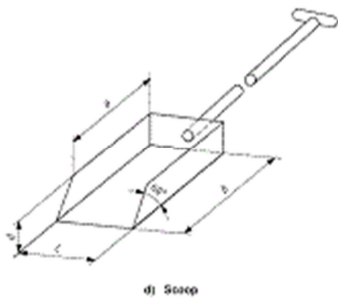

Figure 5. AOAC sampling plan – Hopper cars.

Sampling Apparatus



d) Scoop

Figure 6. Flat-bottomed shovel or scoop with vertical sides.

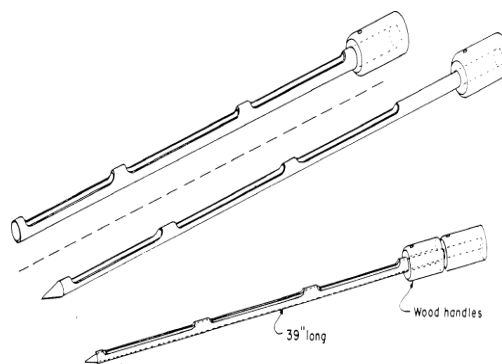

DOUBLE TUBE TRIER

Figure 7. Double tube trier.



Figure 8. Transfer of core sample from Missouri "D" tube into intermediate container.

Note: A slotted double tube trier (Figure 7) is the recommended apparatus for probe sampling.

Sampling Apparatus



Figure 9. Example of Mechanical Probe Sampler.



Figure 10. Example of Mechanical Probe Sampler.