

IFA Technical Conference

Chennai, India

24-27 September 2002

MILLING PHENOMENON EXPERIENCED IN THE PRIMARY REFORMER OF AN AMMONIA PLANT AT NFCL – KAKINADA (a)

Ch Varahalu*, G Kameswara Rao** & V Sunder***,
Nagarjuna Fertilizers and Chemicals Ltd., India

1. Preamble

Nagarjuna Fertilizers and Chemicals Limited operates a large modern integrated ammonia-urea complex laid out in two streams each with a set of ammonia and urea plants. The manufacturing facilities are located at Kakinada in the East-Coast of India in the state of Andhra Pradesh. Stream-1, which was commissioned in July 1992 comprises a 900 MTPD ammonia plant and matching 1500 MTPD urea plant and is fully based on natural gas both as feed and fuel. The ammonia plant is based on Haldor Topsoe's steam reformation process and the urea plant on Snamprogetti's ammonia self-stripping process. Stream-2, which was the result of an expansion programme undertaken by NFCL was commissioned in March 1998. The Stream-2 plants are of identical capacity and based on the same process technology as Stream-1. However, the Stream-2 ammonia plant was originally designed to operate either on 100% naphtha or natural gas both as feed and fuel but not a mixture of the two. The Stream-2 was commissioned with full naphtha and was operated for more than a year. Subsequently, due to availability of more natural gas to the complex in-house modifications were undertaken to enable the Stream-2 ammonia plant operate on a mixture of naphtha and natural gas both as feed and fuel. Presently, this plant is operating on a mixture of naphtha and natural gas in varying proportions based on the availability of natural gas.

The Offsite facilities include raw water pre-treatment and de-mineralisation, compressed air, inert gas (Nitrogen) generation, tanks for ammonia storage at atmospheric pressure, floating-roof naphtha storage tanks, urea silo, bagging plant, effluent treatment plant, high pressure steam (105 ata and 520 °C) auxiliary boilers, gas turbines with heat recovery steam generation, etc. Both the streams share most of the offsite facilities. Natural gas of about 2.14 MMSCMD is supplied by Gas Authority of India Limited (GAIL) through a 94 KM long pipeline from the gas collecting station and naphtha of about 300 to 400 MTPD is piped in by Hindustan Petroleum Corporation Limited (HPCL) from their naphtha terminal situated about 4 KM away. The raw water requirement is met from a large reservoir located 13 KM away and the water is drawn into the complex by means of gravity through two, one meter diameter concrete pipelines. The steam networks and a number of process gas lines are interconnected between both the streams to allow operating flexibility under various conditions.

This paper describes a rare phenomenon experienced immediately during the start-up following the plant turnaround in May 2000 by NFCL in the primary reformer of Stream-1 ammonia plant that baffled the operating personnel.

* Asst. General Manager (Process Plant-1)

** Dy General Manager (Plant Operations)

*** General Manager (Works)

Email :SundarV@nagarjunagroup.com

2. Process Technology

The ammonia plant utilises conventional natural gas steam reformation process of Haldor Topsoe. The major process steps are hydro desulphurization of natural gas, primary and secondary reforming, high and low temperature shift conversion, CO₂ removal by Giammarco Vetrocoke process, methanation, synthesis gas compression followed by ammonia synthesis and separation. The synthesis loop operates at 140 ata and has a purge gas recovery unit (PGRU) built in at the grass root stage itself. The Giammarco Vetrocoke process employs dual (glycine and diethanol amine) activated potassium carbonate solution and there are two regeneration towers to make it a low energy process. As a result of PGRU, the primary reformer operates at high exit methane content of 14% and the secondary reformer 0.6% methane at its exit.

3. Description of Primary Reformer

The primary reformer is a typical Haldor Topsoe side fired box type heater having 190 catalyst tubes arranged equally in two chambers. The furnace consists of 360 radiant wall burners fired with natural gas. The burners are mounted equidistantly in six horizontal rows on the two walls of each chamber. The catalyst tubes are centrifugally cast and internally machined 25 Cr 35 Ni micro alloyed with Nb (equivalent of manaurite 36 Xm) with 152 mm outer diameter and 11 mm wall thickness. The catalyst tubes are packed with 5.6 M³ of pre-reduced catalyst (R-67R-7H) and 21.8 M³ of unreduced catalyst (R-67-7H) supplied by Haldor Topsoe. The nickel impregnated catalyst is in the form of cylinders of 16 mm OD x 11 mm height with seven holes.

The inlet gas distribution system consists of a header and 95 inlet pigtailed for each chamber. The inlet pigtail is connected to the catalyst tube at the top by means a flange and gas enters the tube axially at the top. The outlet distribution system consists of five hot collectors to which a bank of 19 tubes from each chamber is connected by means outlet pigtailed. The hot collectors in turn deliver the process gas into a refractory lined common cold collector. Please refer to Fig.1 for a general arrangement of the system.

The convection section has extensive heat recovery viz. heating of mixed feed (NG + steam), process air, steam superheating and combustion air preheating. The draft inside the primary reformer is maintained at minus 7 mm WC by a combination of forced and induced draft fans. Though the design process gas temperature at the exit of primary reformer is 767 °C in actual operation taking advantage of the PGRU, the process gas temperature is being maintained in the range of 725 to 730 °C. The tubes' skin temperature is not allowed to exceed 880 °C during the operation. The flue gas exits the radiation section at about 980 °C and finally the convection section at 190 °C.

4. High Pressure drop across Primary Reformer

The initial charge of the catalyst was loaded in 1992 just prior to the commissioning of the plant and lasted till 2000. Due to aging, the catalyst showed signs of de-activation and hot bands were observed on most of the catalyst tubes a few months prior to the plant turn-around

in May 2000. This resulted in restrictions like reduced reformer firing, lower process gas temperature at the reformer outlet, etc. Hence it was decided to change the entire catalyst charge and the catalyst in all the 190 tubes was replaced afresh during the plant turn-around.

The unloading of the spent catalyst and loading of the fresh catalyst was done following the usual procedures specified by Haldor Topsoe. Unloading of catalyst was carried out with the help of vacuum blower and fresh catalyst was loaded by using small canvas socks (each of 7 kgs capacity) strictly following the procedure given by Haldor Topsoe. Each catalyst tube was loaded with pre-reduced catalyst (R-67R-7H) at the top followed by unreduced catalyst (R-67-7H). In each tube, an outage (free space) of 0.25 meter was left at the top as originally specified by HTAS as shown in Fig 2. A total of 7.35 m³ of pre-reduced and 20.35 m³ of unreduced catalyst was charged into 190 tubes. Prior to charging of the fresh catalyst, the pressure drop was measured across each of the empty tubes and after loading the catalyst, across each of the loaded tubes. These were found to be 0.14 ksc to 0.16 ksc for the empty tube and 0.6 to 0.7 ksc for the fully loaded tube respectively.

The reformer was pressed into operation with nitrogen circulation at 9:00 hours on 22 May 2000 and feed was introduced at 07:00 hours on the 23 rd with about 40% rate and a steam to carbon ratio of 5.95. The pressure drop across the primary reformer as measured between the common gas inlet header and the cold collector was 0.95 ksc. The plant load was further increased to 65% by 23:00 hours and was maintained at the same load till 9:00 hours on the 25th may. The pressure drop during this period remained at 1.1 ksc. Plant load was gradually increased to 105% by 05:00 hrs of 26th May. At this point the steam to carbon ratio was 3.5 and the pressure drop 2.28 ksc. A few minutes later the pressure drop started rising slowly and reached 2.71 ksc. by 17:00 hrs. From 17:00 hours the rate of rise in pressure drop was rather high and it crossed 5 ksc by 19:00 hours. At this juncture, the operating personnel became a little perturbed and reduced NG feed rate to 70% but without corresponding reduction in the steam quantity to the primary reformer so as to ensure more than normal steam to carbon ratio. The normal point of introduction of recycle hydrogen is in the hydro desulphurization section. A provision also exists for introduction of recycle hydrogen at the inlet of the primary reformer. The recycle hydrogen flow to the desulphurization section was increased from 1000 to 1500 Nm³/hr. Simultaneously, recycle hydrogen was also introduced to the primary reformer and the flow rate was kept at 2200 Nm³/hr. The feed natural gas temperature at the exit of the pre-heater in the desulphurization section was also increased from 315 °C to 335 °C. Not with standing all these actions, the pressure drop continued to increase and reached 9.2 ksc by 22:00 hrs. The plant load was reduced further to 40% and there was no much rise in pressure drop. These actions were taken in apprehension of either sulphur poisoning and /or carbon lay down of the catalyst in the primary reformer.

Figure 3 shows the profile of steam and feed gas flow to the primary reformer and Figure 4 shows the profile of the pressure drop across the primary reformer.

During this time the appearance of the catalyst tubes was continually monitored both visually and by measurement of tube skin temperature. All tubes appeared normal and no abnormalities like hot spots, hot bands were seen and the skin temperature on all the tubes was normal. Hence it was felt that there was a common reason for all the tubes for the high-pressure drop. It was suspected that it could be sulfur poisoning, carbon lay down, abnormal variation in the feed NG composition or physical blockage in common process gas path like inlet header / outlet cold collector.

So the feed natural gas composition, sulphur content in the desulphurized NG at various points like the out let of NiMox bed and both zinc oxide beds, inlet and outlet of primary reformer, etc, were analyzed and found to be normal.

The hydro de-sulphurisation exit gas analyzed had less than 0.05-ppm sulphur. Since the pressure drop across the primary reformer was still remaining high (10 ksc) even at 40% plant load, it was decided to take a shut down of the plant and inspect physically the catalyst condition in the tubes and for any blockage in the common gas path. So the natural gas feed was cut off at 5.00 hrs on May 26 and the primary reformer was cooled down.

First the manways of the cold collector were opened. All the refractory was found intact and no blockages were found in the gas path. Next, to look at the catalyst, the inlet flanges of a few reformer tubes were opened. The catalyst in these tubes was found to be broken into pieces, partly powdered and the catalyst mass up to a depth of about 150 mm was found to be crusted. Figure 5 shows the portion of the crushed catalyst. Figures 6 A, B and C show the appearance of the catalyst pellets at the top in side the tubes. Interestingly enough, some of the catalyst cylinders were found to have rounded edges and surface. In Figure 7, rounded edges of the catalyst pellets can be seen clearly. Subsequently inlet flanges of all the remaining tubes were opened and the same phenomenon was noticed in all the tubes. The condition of the catalyst beyond the depth of about 150 mm was, however, found to be normal in all the tubes. Haldor Topsoe were apprised of the events and as advised by them the catalyst was removed to a depth of 0.75 meter in all the tubes. Then the pressure drop across each tube was measured and found to be more or less matching with the original values obtained in May 2000 at the time of filling the fresh catalyst. Random catalyst samples at 0.75meter depth were collected from a few tubes and were analyzed for carbon deposition and sulphur pick up. Neither carbon nor sulphur was present in the samples. Catalyst samples were also collected at a depth of 1 meter and 2 meters from a few tubes. Here too no carbon or sulphur was found and the physical condition of the catalyst was found to be good. Further, two more tubes were fully unloaded to check the catalyst condition and the catalyst was found to be good.

Haldor Topsoe explained that a phenomenon called “catalyst milling” had occurred in the top layer of the catalyst, which was the reason for the high-pressure drop and there were a few reported instances of such occurrences in other plants. The phenomenon of milling is the breakage of catalyst into fine particles or powder and crusting, as a consequence of rapid swirling of catalyst due to impingement of high velocity gas on the catalyst surface.

Milling is very likely to occur during the restart of the primary reformer after charging fresh catalyst and if the plant load is increased rapidly to 100% or beyond. When the plant load is increased gradually, the catalyst will have enough time to settle down and the likelihood of the process gas jet impinging on the catalyst surface is very less as the gas approaching the catalyst surface will have enough distance to diverge fully across the entire tube cross section due to settling of the catalyst.

Haldor Topsoe advised us to top up all the 190 tubes with fresh catalyst leaving an outage of 0.40 meter (Figure 8) and also to increase the plant load gradually during the start up so as to avoid the possibility of catalyst milling.

Following Topsoe’s advice the catalyst was topped up and the plant was restarted on 31.05.2000 at 02:30 hours with nitrogen circulation. The feed to the reformer was introduced

at 40% plant load at 10:00 hours on the same day with 2000 Nm³/hr recycle H₂ to reformer and 1000 Nm³/hr recycle H₂ to the de-sulphurization section. The pressure drop across the reformer was just less than 1.0 ksc. Plant load was gradually increased to 50% by 22:00 hours. The ammonia production was lined up on 01.06.2000 at 06.00 hrs. Thereafter the plant load was further increased gradually to 87% by 13:00 hours on 1 June and to 100% by 01:00 hours on 2 June. The pressure drop was recorded as 1.72 ksc. Further the plant load was increased to 115% by 14:00 hours on 4 June and the pressure drop was 2.05 ksc. Thereafter, the pressure drop across the primary reformer was watched closely and it remained at 2.05 for the next five days. Later the plant load was increased to 122 % and the pressure drop leveled out at 2.31 ksc.

5. Learning Experience

As a consequence of rapid restart of the primary reformer after charging fresh catalyst, NFCL experienced the ‘milling’ phenomenon due to which the pressure drop across the primary reformer rose very steeply and forced the plant shutdown. Based on NFCL’s experience

- I. Increasing the free space above the catalyst in the tube, and
- II. Raising the plant load gradually and with longer waiting periods between the steps are the measures to avoid the occurrence of milling.

Figure 1

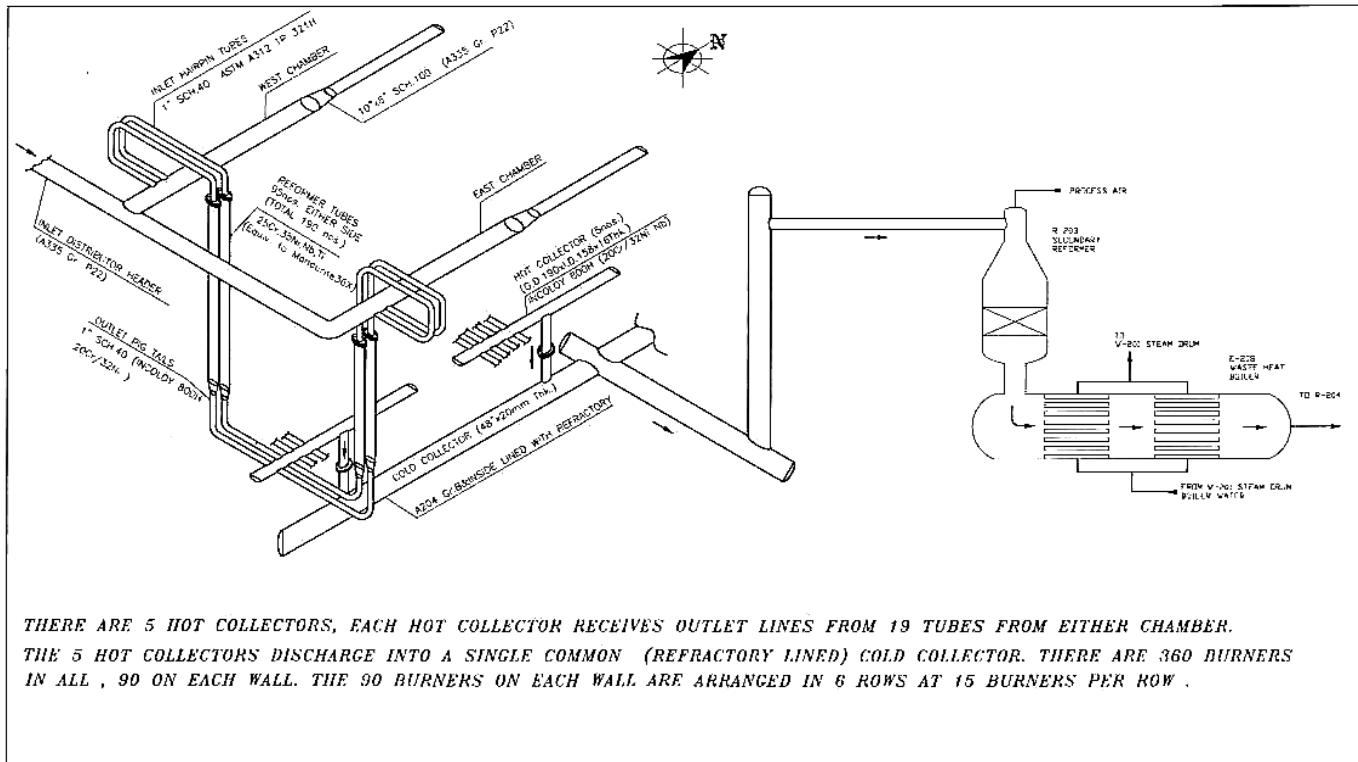
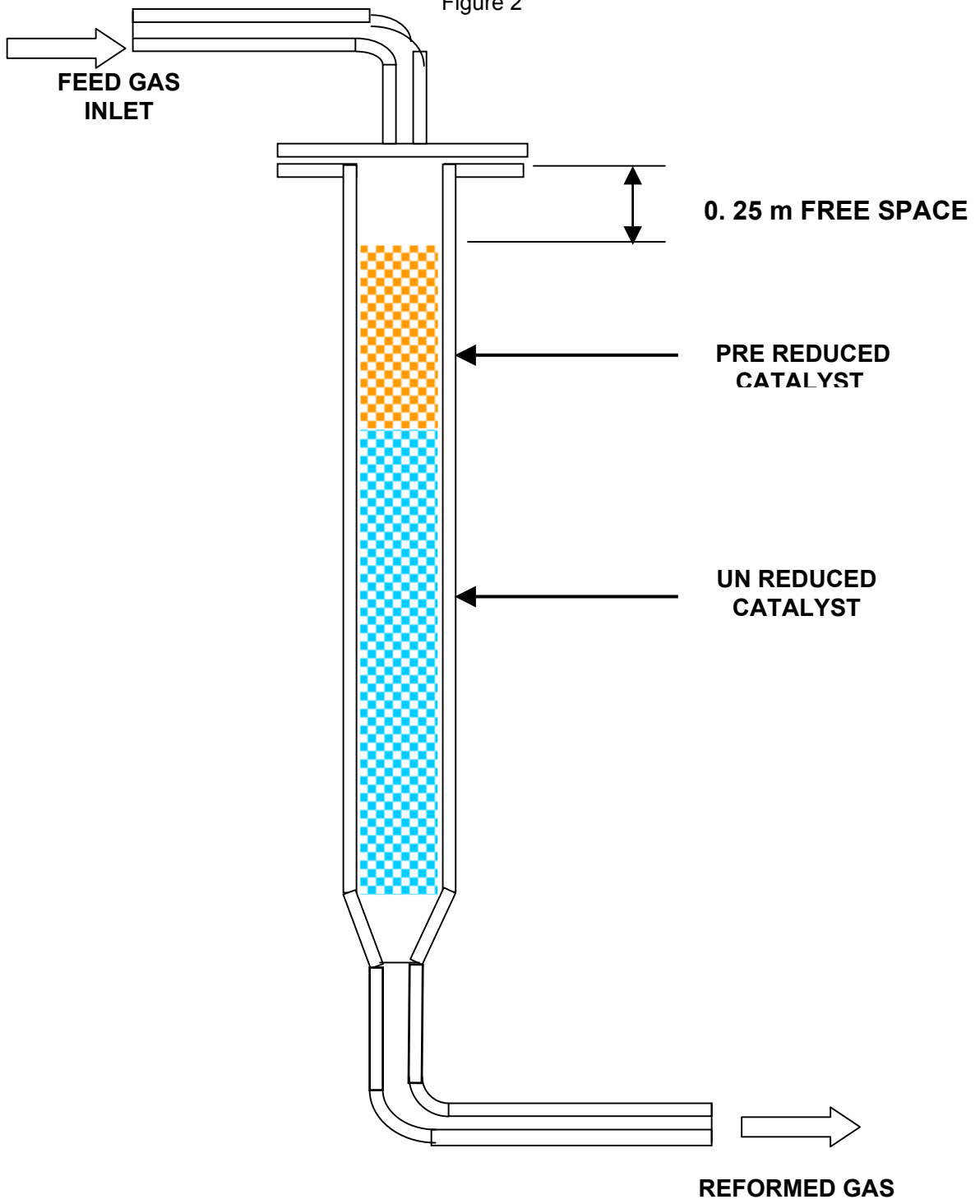

Figure 2



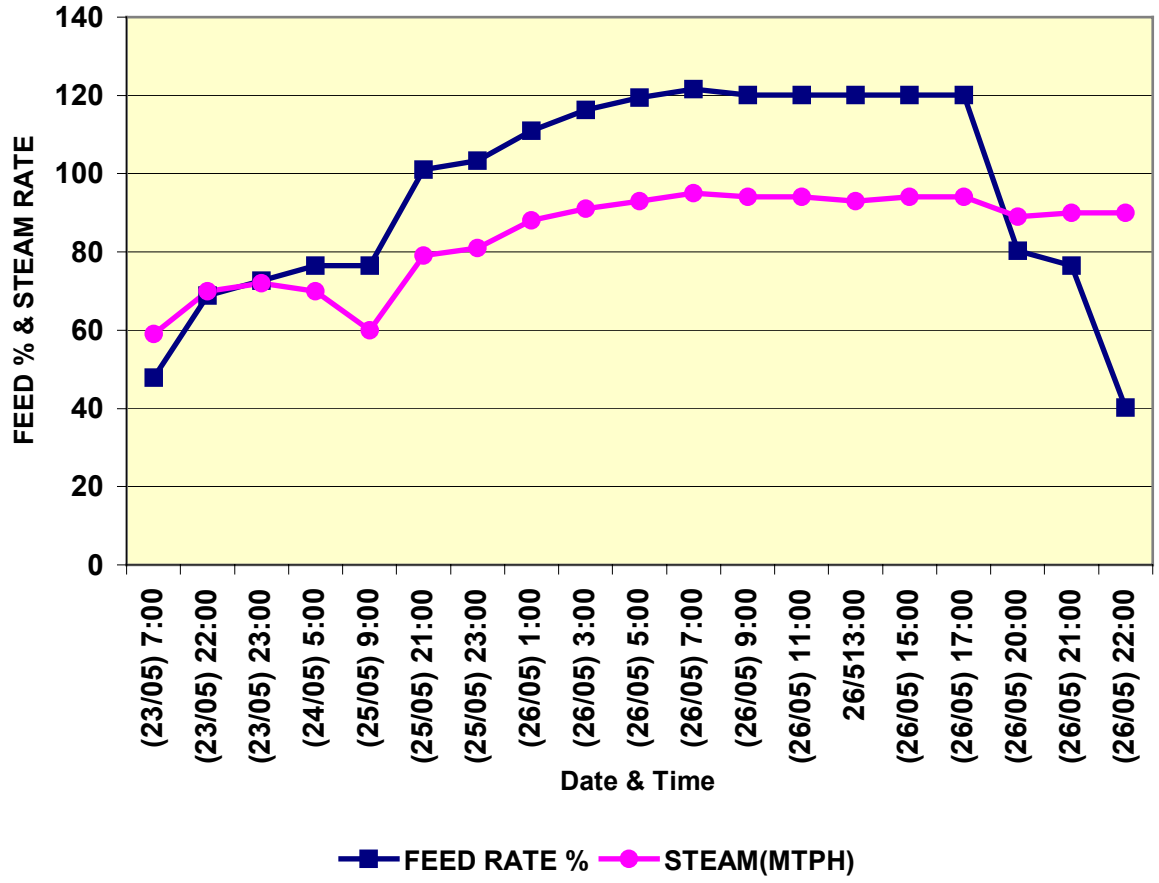

Figure 4

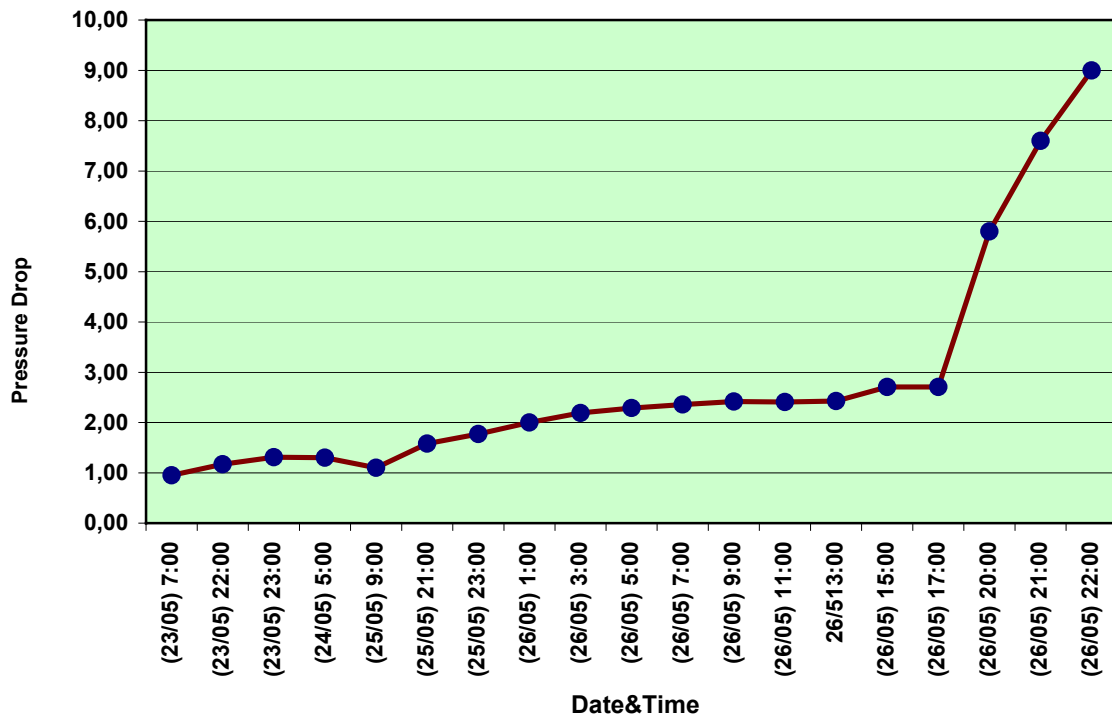

Figure 5

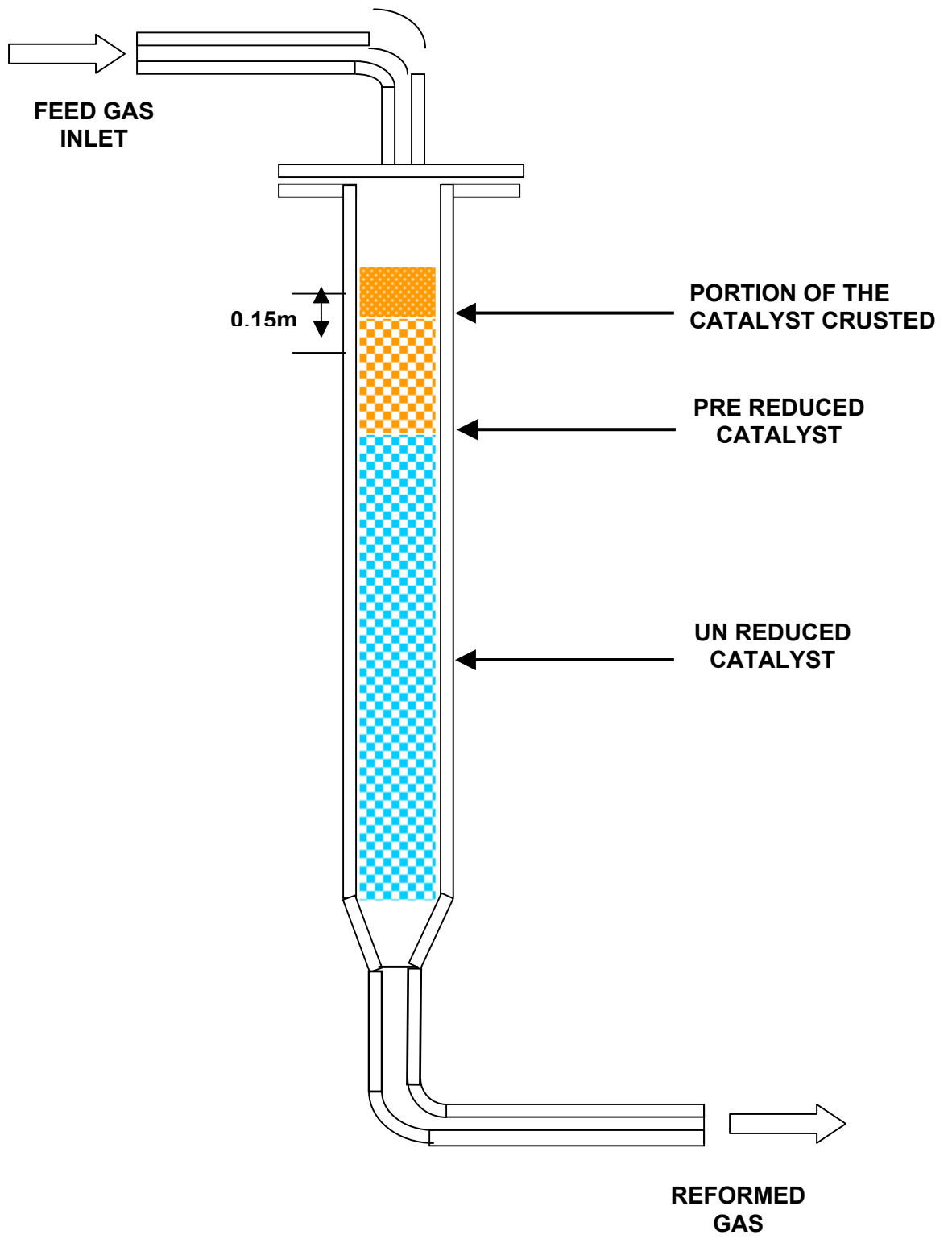

Figure 6A



Figure 6B



Figure 6C

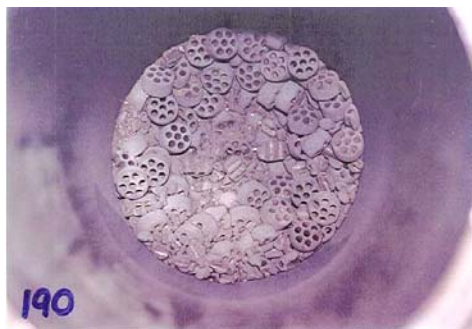

Figure 7



Figure 8

