

# IFA Technical Conference

Chennai, India

24-27 September 2002

# STRETCHING THE CAPACITY OF A 23-YEAR OLD KELLOGG AMMONIA PLANT (a)

V.S. Vaish\* and M.R. Patel\*\*, IFFCO, India

The IFFCO Kalol ammonia plant of 910 tpd, based on natural gas steam reforming process of M.W. Kellogg, USA was commissioned in 1974. The plant was operating near rated capacity. Since commissioning various modifications were carried out to improve operational reliability, safety and debottlenecking. In 1993, synthesis converter retrofit and primary reformer revamp were carried out. This gave the margin for capacity enhancement. In 1995, it was planned to stretch the capacity of ammonia plant from 910 t/d to 1100 t/d with additions such as natural gas booster compressor to sustain the plant operation, pre-reformer to use naphtha as feed along with gas in existing primary reformer, air compressor revamp, MEA solution swap with a-MDEA in CO<sub>2</sub> removal, suction chiller for synthesis gas compressor, DCS & PLC. This paper describes the methodology adopted for stretching the ammonia plant capacity. Increase of capacity in existing plant proved much less capital intensive compared to new grassroot plant.

## 1. Introduction

IFFCO is a multistate co-operative society engaged in the production and marketing of fertiliser. It is the first in co-operative sector to enter the Indian fertiliser industry. During the sixties, fertiliser demand exceeded production and it was the sellers' market. Farmers, the main customers of the fertiliser were facing difficulties in getting the required quality and quantity in time. Small village level co-operatives of farmers with the state level apex body joined hands in the formation of Indian Farmers Fertilisers Cooperative Ltd. popularly known as IFFCO. When IFFCO was started as a co-operative society in 1967, finance was one of the major constraints. During those days, co-operative societies were small in operation and their performance was not to the satisfaction.

Success of IFFCO set a new trend not only in the co-operative sector but also revolutionised the fertiliser industry. The march towards fulfillment of IFFCO started with its first plant at Kalol.

## 2. Technology Selection

For the success of any industry, selection of technology and its appropriate management play major role. In IFFCO, it was chosen to have on-site analysis of various technology plants. A top management team visited many plants for on-site information on capacity utilisation, onstream factor, operational stability and energy consumption. During their visit, M.W. Kellogg who designed plants of C.F. Industries, Donaldsonville USA was found to be most suitable, the largest single stream plant with the least energy consumption at that time. Thus a turnkey contract was awarded for IFFCO Kalol 910 tpd gas based ammonia plant based on M.W. Kellogg steam reforming technology. Ammonia plant was commissioned in November

---

\* Senior General Manager, Kalol Unit

\*\* Chief Manager (Process), Kalol Unit

Email: [mrpatel@iffco.nic.in](mailto:mrpatel@iffco.nic.in)

(a) received on 25/06/02

1974. Natural gas supplied by ONGC, available in the vicinity of the plant, was used as feed stock for the ammonia plant. Associated gas, naphtha and furnace oil were used as fuel for the ammonia and urea plants.

### **3. Salient Features of the Plant as Installed**

Steam natural gas reforming, two stage shift conversion, MEA CO<sub>2</sub> removal system, synthesis compressor having high pressure and medium pressure steam turbines running at tandem, low pressure synthesis loop, hot ammonia transfer facility for urea plant, DM water as CT make-up, chromate as corrosion inhibitor in cooling water system, auxiliary steam generation integral to primary reformer furnace and independent from the power failure were the salient features of this plant. Specific consumption of inputs and energy consumption were the lowest at that time.

### **4. Kalol Expansion Project**

To improve the fertiliser availability in the country with the least investment, the capacity of ammonia plant was increased from 910 tpd (300300 tpa) to 1100 tpd (363000 tpa) and urea plant from 1200 tpd (396000 tpa) to 1650 tpd (544500 tpa) in August 1997. Based on the detailed in-house study, various measures were implemented for stretching the ammonia plant capacity. Block diagram of ammonia plant showing the new additions/modifications is shown in Figure 1. The measures implemented are described in detail in this paper.

#### **4.1 Pre-reformer**

Supply of natural gas, the feed stock, is depleting day by day. Lower gas supply restricted the plant operation at higher load. To sustain the operation at higher load, an alternate feed stock was inevitable. Using naphtha as a feed stock in conventional form was not possible due to primary reformer catalyst volume limitation. Pre-reformer system was considered the best option and was adopted to pre-reform naphtha so that this can be used as feed in primary reformer.

Pre-reformer system, a complete add-on unit was installed, based on Haldor Topsoe AS of Denmark, at the cost of Rs. 173.8 million (circa USD 4.6 million), to produce partially reformed gases equivalent to 350 tpd ammonia. Process flow diagram of pre-reformer system is shown in Figure 2. The pre-reformer system consists of naphtha deaeration, naphtha pre-heating, hydrogenation, desulphurisation, naphtha superheating and finally naphtha pre-reforming. For sulphur removal, only CO-Mox and ZnO beds are installed. Naphtha is reformed to lighter hydrocarbons. The pre-reformed naphtha is mixed with natural gas feed at the upstream of the primary reformer. The add-on unit can easily be taken in and out of operation without obstructing the ammonia production from the rest of ammonia plant.

##### **4.1.1 Benefits of the Pre-reformer system**

a	Reduction in severity of furnace firing of the primary reformer furnace at same plant load. This increases flexibility in primary reformer for higher load operation.
b	There is improvement in life of primary reformer catalyst due to presence of H <sub>2</sub> in feed gas to primary reformer from pre-reformer.

#### 4.1.2 Constraints and problems faced

a	The sulphur absorber catalyst volume is 19.3 m <sup>3</sup> for 2 to 3 years of catalyst life with 100 ppm sulphur present in the feed stream. High sulphur in feed naphtha is one of the main constraints.
b	Pre-reformer system is designed for 12 % aromatic in feed naphtha with maximum flexibility to operate up to 18 % aromatic with aromatic slip of about 2000 ppm. Higher aromatic slip can damage the primary reformer catalyst.
c	Pre-reformer system trips during power failure. After resuming power supply, pre-reformer system is lined-up with ammonia plant. With tripping of pre-reformer, process air to secondary reformer for H <sub>2</sub> : N <sub>2</sub> ratio control and primary reformer fuel firing for furnace temperature control is required immediately.
d	Earlier tail gas from PGR was used for deaeration of naphtha; however during power failure, naphtha carry-over problem was faced. Now associated gas is used for deaeration of naphtha.
e	Initial start-up was delayed due to limitation of final vent control valve at the exit of pre-reformer. Vent control valve (Cv) was designed based on operating pressure of 36.2 kg/cm <sup>2</sup> g. In actual operation, during start-up, system pressure remains only 5 to 6 kg/cm <sup>2</sup> g. Afterwards vent control valve has been redesigned. Now there is no such problem.

#### 4.2 **Process Air compressor (101-J) revamp**

Process air compressor supplying air to secondary reformer was designed for 910 tpd production and was limiting the plant operation at higher load. To revamp the process air compressor, following options were studied:

a	Air compressor revamp by changing internals of LP and HP case along with drive turbine upgrade.
b	Installation of parallel compressor.
c	Installation of suction booster.
d	Suction chiller along with the suction booster.

Installation of parallel compressor, suction booster or suction chiller along with the suction booster brings in new additional equipments. Integration of these additional equipments with existing compressor hampers the reliability of the plant. Considering the control logic, operating philosophy, energy efficiency and space limitation in the existing lay out, revamping of air compressor train by changing internals of LP and HP case along with turbine upgrade became the best option.

The existing LP case rotor 4 CK 30/20 and HP case rotor 7 CK 14/8 were replaced with new drop in bundles. LP case rotor was replaced by 5 CK 57 and HP case rotor with 8 CK 31. For fitting the new LP case rotor, an in-situ additional grooves were made on the casing, with the help of Mannesmann Demag Delaval, USA.

To match the power requirement at higher load, turbine was upgraded from 9605 HP to 13095 HP. For upgrading the turbine, diaphragms of last two stages and nozzle block were modified. The entire job of train revamp was carried out in plant turn around in 28 days.

Total cost of process air compressor revamp was Rs. 77.3 million (circa USD 2 million). To reduce the total cost of air compressor train revamp, Mannesmann Demag Delaval, bought back the old spare rotors and other spares.

Normal operating data of process compressor before and after modification are given in Table 1.

Table 1: Operating data of air compressor train

Sr. No.	Particulars	Unit	Before modification		After modification	
			1 <sup>st</sup> stage	2 <sup>nd</sup> stage	1 <sup>st</sup> stage	2 <sup>nd</sup> stage
	LP case					
1	Inlet temperature	<sup>o</sup> F	95	105	113	120
2	Inlet pressure	psia	14.5	33.4	14.5	31.5
3	Discharge temperature	<sup>o</sup> F	291	279	305	320
4	Discharge pressure	psia	34.4	70.0	32.5	73.7
5	Normal capacity	lb/min	1665.9	1646.6	2154.0	2105.4
6	Speed	rpm	6740		6740	
	HP Case		3 <sup>rd</sup> stage	4 <sup>th</sup> stage	3 <sup>rd</sup> stage	4 <sup>th</sup> stage
7	Inlet temperature	<sup>o</sup> F	105	105	120	120
8	Inlet pressure	psia	67.7	179.6	70.7	191.0
9	Discharge temperature	<sup>o</sup> F	361	369.6	373.2	373.9
10	Discharge pressure	psia	184.6	490	196.0	510.0
11	Normal capacity	lb/min	1628.3	1605.0	2064.5	1989.7
12	Speed	rpm	10900		10900	
13	Increase in capacity	lb/min				384.7 (23.97 %)

After the air compressor train revamp in May - June 1997, the machine started at a speed of 6600 rpm. Even at this speed there was high amount of air venting from the final discharge vent valve, as ammonia plant was operating at a lower load to produce the matching ammonia for urea production.

Performance curve of the revamped process air compressor as supplied by the supplier is shown in Figure 3.

Figure 3: Performance curves of revamped process air compressor

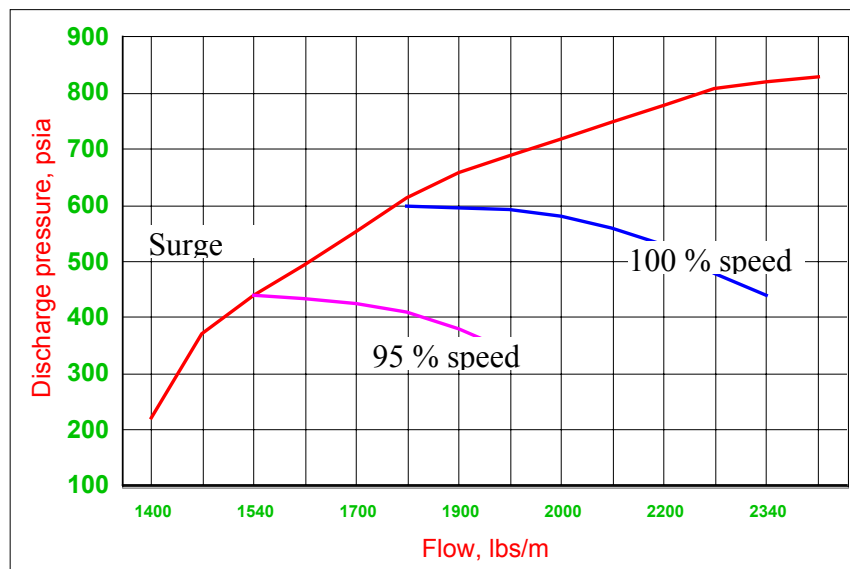

Based on the experience, IFFCO decided to reduce the machine speed to stop the venting of air, in steps. As the confidence builds-up at one speed, then it was further reduced. The air compressor train data are tabulated in Table 2.

Table 2: Air compressor train speed reduction data

Sr. No.	Period	Speed, rpm	Ring pressure, kg/cm <sup>2</sup> g	Steam consumption, kg/h
1	Commissioning period, May 1997	6800	19.7	54000
2	June 1997	6600	17.7	47500
3	December 1998	6550	16.5	44500
4	August 2000	6450	15.5	42000

Since June 1997, there is a speed reduction by 150 rpm. This resulted in the savings of 5500 kg/hr MP steam. Still, there was some venting of air. To utilize this, HP air from compressor discharge is supplied to utility plant for instrument air and plant air purpose. This has stopped all the five compressors in the utility plant, which resulted in the power savings of 375 kWh.

### 4.3 CO<sub>2</sub> removal section revamp

For stretching the plant capacity from 910 tpd to 1100 tpd, the CO<sub>2</sub> removal section was also a bottleneck. The main criteria of CO<sub>2</sub> removal process selection was utilization of all the existing equipments, with the least CO<sub>2</sub> slip and low energy requirement. Space was not available for addition of new equipments.

CO<sub>2</sub> removal is a significant step in ammonia production process with respect to investment and energy consumption. With the fast increasing energy costs, the CO<sub>2</sub> removal processes are being continuously improved. Salient features of different CO<sub>2</sub> removal processes are given in Table 3.

Table 3: Salient features of different CO<sub>2</sub> removal system

Parameters	MEA UOP-II	MEA UOP IV	Benfield	Glycine Vetrocokε	a-MDEA Straight solution Swap	a-MDEA Single stage	a-MDEA Double Stage	Selexol
CO <sub>2</sub> purity %	99.0	99.0	98.5	99.4	99.5	99.95	99.95	98.5
CO <sub>2</sub> slip in product gas, ppm	100	100	500	300	100	100	100	500
Design energy kcal/kgmole of CO <sub>2</sub>	36000*	25000	19000	16000	32000	29000	9500	6000@

\* Based on the actual plant data.

@ Additional refrigeration system is required for Selexol process.

Table 3 clearly reveals that, the activated MDEA process was the most energy efficient process, suitable under the prevailing plant conditions.

There are following three alternatives for revamping the existing CO<sub>2</sub> removal section, with a-MDEA process:

- 1) Straight solution swap.

- 2) Single stage a-MDEA process.
- 3) Two stage a-MDEA process.

Considering the steam network of the plant and utilisation of all the existing equipments i.e. no addition of new equipments, MEA UAG-II system was revamped to straight solution swap, with the cost of Rs. 48.7 million (circa USD 1.25 million). The energy requirement and operating parameters of both the process are summarised in Table 4.

Table 4: Energy requirement and operating parameters

Sr. No.	Parameters	Unit	With MEA UAG-II	With a-MDEA
1.	Plant load	tpd	910	1100
2.	Reboiler duty	Gcal/h	40	35
3.	Energy requirement for CO <sub>2</sub> removal	kcal/kgmole	36000	26000
4.	Energy savings	Gcal/t of NH <sub>3</sub>	---	0.29
5.	Solution circulation rate	m <sup>3</sup> /hr	780	700
6.	CO <sub>2</sub> slip in raw syn gas	ppm	<100	<250
7.	CO <sub>2</sub> product gas purity	%	99	99
8.	Stripper temperature	deg C		
	Top		93	90
	Bottom		118	115

Design energy requirement for solution regeneration is 32000 kcal/kgmole of CO<sub>2</sub> removed, however in actual operation at IFFCO Kalol, the energy requirement is 26000 kcal/kgmole of CO<sub>2</sub> removed (reduction by 28 %), i.e. much lower than the design value. Reboiler steam requirement is about 15 t/h against earlier steam consumption of about 25 t/h even though CO<sub>2</sub> removal requirement is higher by 27%. IFFCO Kalol is the first plant in the country to revamp the existing CO<sub>2</sub> removal system by straight solution swap.

#### 4.3.1 Change over from MEA to a-MDEA system

For smooth change over, all the equipments of CO<sub>2</sub> removal section were thoroughly cleaned with DM water. Exchangers were hydro-jetted from shell and tube sides. System was again filled with DM water and 4 % K<sub>2</sub>C<sub>3</sub> solution and the temperature in the system was maintained at 700 C by lining up steam in the reboilers. Solution was circulated for 15 hrs. Then the solution was drained, and the system was again filled with DM water. a-MDEA was charged and concentration was slowly increased to 40 %. Following problems were faced during the lining up of a-MDEA system:-

##### (A) Foaming problem

When activated carbon bed filter was taken in line foaming severity increased, resulting in higher requirement of anti-foamer. Also, this increased the reflux, higher concentration of a-MDEA in reflux and higher hydrogen concentration in product CO<sub>2</sub>.

Hydrogen concentration reached as high as 1.2 to 1.4% (V/V) from 0.8 % V/V. Higher dosing of anti-foamer agent did not reduce the foaming tendency. Anti-foamer consumption remained very high. Mechanical filters, provided at absorber liquid outlet, carbon filter inlet and at carbon filter outlet were cleaned and found that lot of anti-foamer is being removed in the filters. When activated carbon bed was isolated, the foaming tendency was reduced. With time, the system has become stable and is working extremely well.

**(B) Stripper inlet distributor failure**

During the change over, the size of the distributor pipe in both the CO<sub>2</sub> strippers was increased from 10 inches to 12 inches. Size of the distributor was increased to take care of higher vapour generation in the a-MDEA system. Even after increasing the size of the distributor pipe, there was failure of the inlet distributor and its supporting system. To overcome this problem, new slots were created on top of the lateral arm of the distributor. In addition to this, a hood is provided above the vapour slots. This has stopped the distributor failure problems.

**(C) Thermosyphon breaking in steam reboiler of strippers**

There are two steam reboilers. Each boiler was originally designed for condensing 31700 kg/h LP steam. After changing over to a-MDEA system, due to low energy requirement, steam flow has come down to about 7000 kg/h in each reboiler. Lower steam requirement has reduced the natural circulation in the reboilers, resulting into the thermosyphoning failure. Due to thermosyphon breaking, steam flow used to vary from 4000 kg/h to 10000 kg/h. Steam flow control valves remained only 1-2 % open and steam flow variations were controlled by throttling the steam line manual valve.

To overcome these problems, internal port of steam flow control valves were replaced to reduce the Cv of the valve. Control logic of flow control (FIC) was changed to steam flow and reboiler level control (FIC-LIC) logic with cascade arrangement of overriding the FIC with LIC. Also, 50 % of the tubes in reboilers were blocked to reduce excess heat transfer area. Now the reboilers are functioning perfectly well.

**4.4 Chiller at synthesis gas compressor suction**

At the uprated plant capacity, the suction volume limitation to synthesis compressor was identified and accordingly a suction chiller was installed at a cost of Rs. 2.2 million, to cool the synthesis makeup gas from 380 C to 80 C. This increased the volumetric capacity of the compressor to produce more than 1100 tpd ammonia without any modification in the machine.

**4.5 Primary reformer arch burners**

Burners in the induced draft primary reformer furnace were dual fuel type, with a central liquid naphtha nozzle and four peripheral gas nozzles, intended to fire either or both fuel together for total heat liberation in any ratio. The original burners, particularly with naphtha firing had following deficiencies:

a	Long, bushy and yellowish flame.
b	Flame impingement on the reformer tubes.
c	Soot deposition on convection zone coils resulting in low heat transfer on those coils.
d	Shorter life of reformer tubes due to uneven flame pattern.
e	Overall poor performance of reformer.

In addition to the above, frequent choking of naphtha guns with gum formation on the tip was experienced. Replacement of burners was a difficult job as it required the extensive modification of the top roof. Minimum roof modification was the primary requirement for burner replacement. After a detailed study, DBA-16 (SPL) burners of John Zink were found

to be most suitable. All 126 nos. arch burners were replaced without top roof modification and the performance has improved manifold.

#### **4.6 Natural gas booster compressor**

Initially natural gas supply pressure was 40 kg/cm<sup>2</sup>g. As the gas wells were depleting, gas supply pressure reduced to 30 kg/cm<sup>2</sup>g. Accordingly a compressor was installed and commissioned in 1984 to take the gas at 30 kg/cm<sup>2</sup>g with a provision of further modification in the existing train to take the gas up to 20 kg/cm<sup>2</sup>g. Again to cope up with the depleting pressure, one more compressor was installed in 1997, during stretching of plant capacity, to boost up natural gas from 10 kg/cm<sup>2</sup>g suction pressure to 20 kg/cm<sup>2</sup>g discharge pressure with an additional provision of compressing associated gas from 2.0 kg/cm<sup>2</sup>g to 4 kg/cm<sup>2</sup>g pressure. The cost of the booster compressor was Rs. 109.7 million (circa USD 2.8 million).

#### **4.7 Distributed control system (DCS) and Programmable logic control (PLC)**

IFFCO Kalol plant was designed with, pneumatic instrumentation, the latest that existed in seventies. It had performed well over the years.

For better control of operation, the entire pneumatic control system was replaced to DCS without affecting the production. In the plant capacity uprate programme, it was decided to install DCS in order to improve the reliability, operating flexibility, ease of control and safety of the plant. Yokogawa based Centum-XL DCS was installed.

Further, HIMA of Germany programmable logic control for critical control loops was installed for safer plant start-ups and shutdowns. PLC and DCS both are functioning satisfactorily and it has added to the safety of the plant.

The most important achievement was that all these change over in instrumentation was done while plant was in operation and not caused even a single interruption. Now the entire operation of the plant is from DCS and the pneumatic panel has been removed totally.

### **5. Conclusion**

Installation of a grass root plant is much easier than stretching the capacity of a 23-years old plant. However, stretching the existing plant capacity is more economical than installing a grass root plant. At IFFCO Kalol, the capacity of the existing ammonia plant was increased from 910 tpd to 1100 tpd (22 % increase) at a cost of about Rs. 773.4 million (USD 19.8 million). The capital investment per tonne is about Rs 4 million, compared to about Rs. 6 million, for a grass root plant. The capital cost at Kalol is significantly lower inspite of inclusion of operational reliability measures like natural gas booster compressor, pre-reformer system and DCS & PLC.

In stretching the capacity of the plant, very few equipments were replaced/modified to remove the bottlenecks. The main equipments like reactors, vessels, rotating machineries, pipings, control and relief valves, commissioned in 1974 were retained.

Stretching the plant capacity was accomplished within cost and ontime. IFFCO Kalol could achieve this due to proper, systematic planning, devoted work force and committed management.

Figure-1

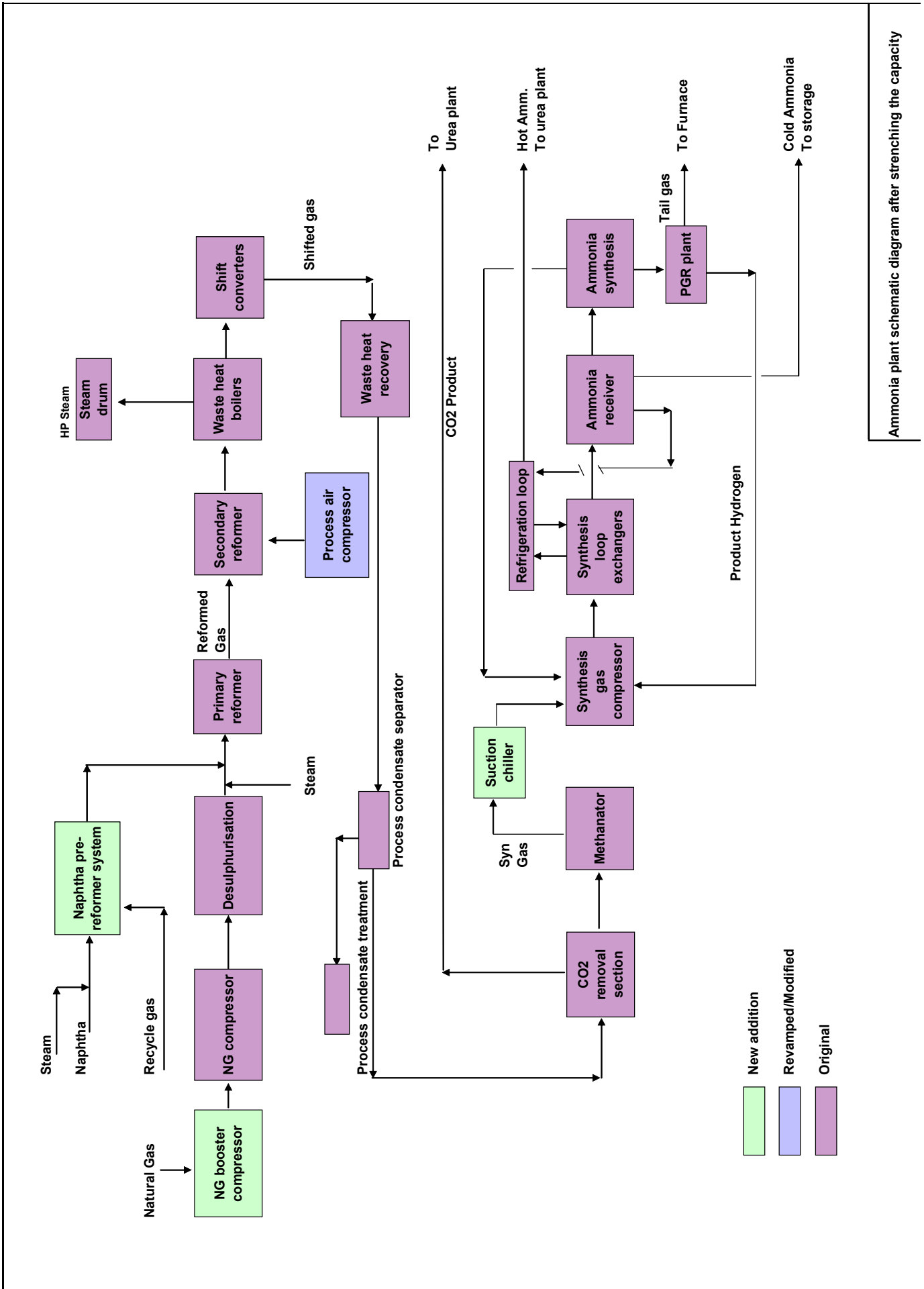

Ammonia plant schematic diagram after stretching the capacity

Figure-2

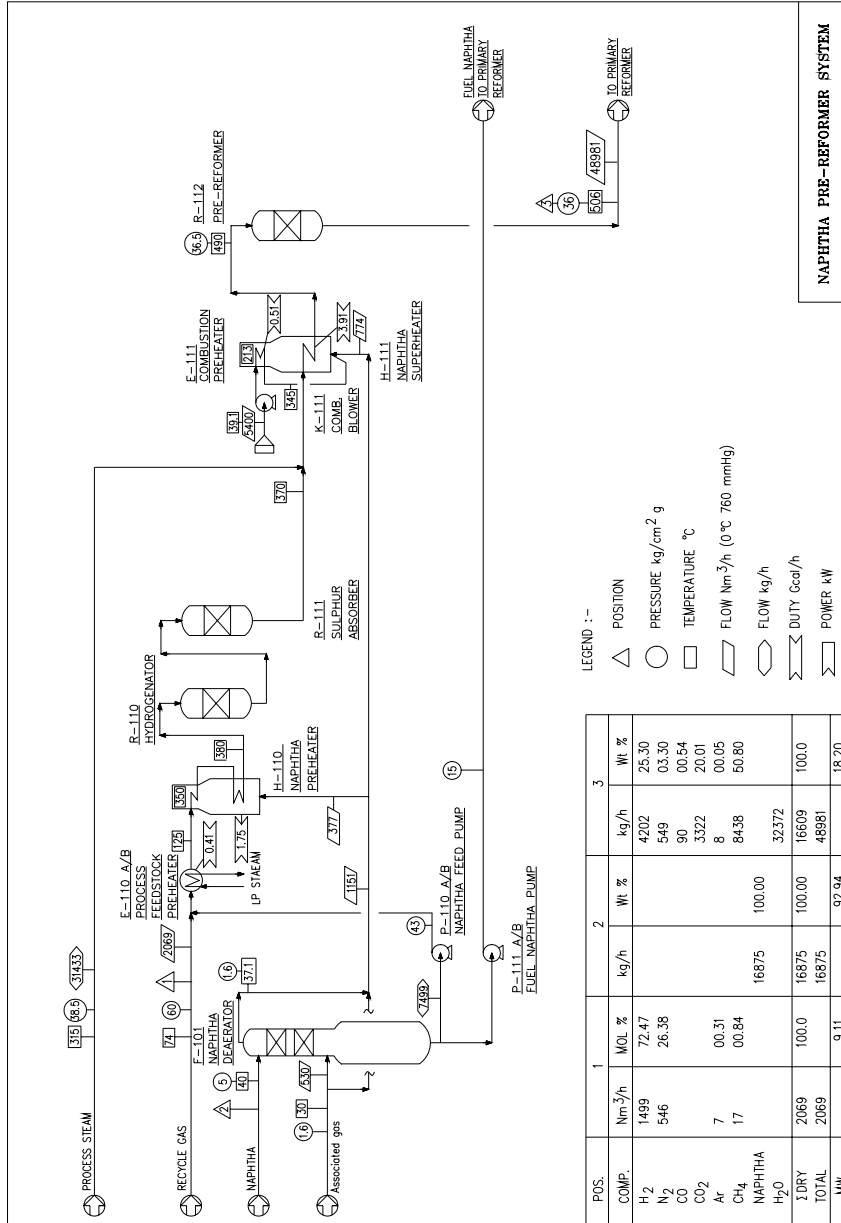

LEGEND :-

- △ POSITION
- PRESSURE kg/cm<sup>2</sup> g
- TEMPERATURE °C
- ▭ FLOW Nm<sup>3</sup>/h (0 °C 760 mmHg)
- ◊ FLOW kg/h
- ≡ DUTY Gcal/h
- ≡ POWER kW

POS.	1	2	3
COMP.	Nm <sup>3</sup> /h	kg/h	kg/h
H <sub>2</sub>	1499	72.47	25.30
N <sub>2</sub>	546	26.38	03.30
CO		90	00.54
CO <sub>2</sub>		3322	20.01
Ar	7	8	00.05
CH <sub>4</sub>	17	84.38	50.80
NAPHTHA		16675	32372
H <sub>2</sub> O		100.00	
T DRY	2069	100.0	16609
TOTAL	2069	16675	48981
NW	9.11	92.94	18.20

NAPHTHA PRE-REFORMER SYSTEM